A black and white photograph of a wind farm. Three wind turbines are visible, arranged in a line from the foreground to the background. The turbines have three blades each. The background shows a field of trees under a bright sky. The overall image has a grainy, halftone texture.

TECHNICAL SPECIFICATION
MICON M530 – 250 KW

M450 / M530 - 250kW

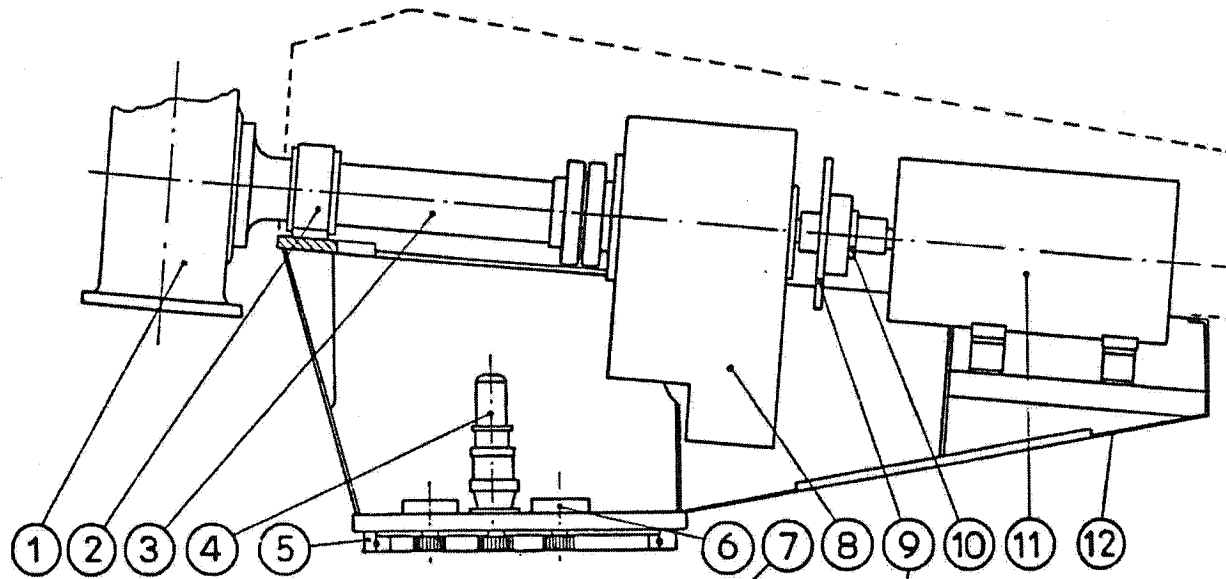

1. Hub
2. Main bearing
3. Main shaft
4. Yaw gear
5. Yaw ring
6. Yaw brake
7. Rubber suspension
8. Gearbox.
9. Brake
10. Rubber coupling
11. Generator
12. Nacelle frame

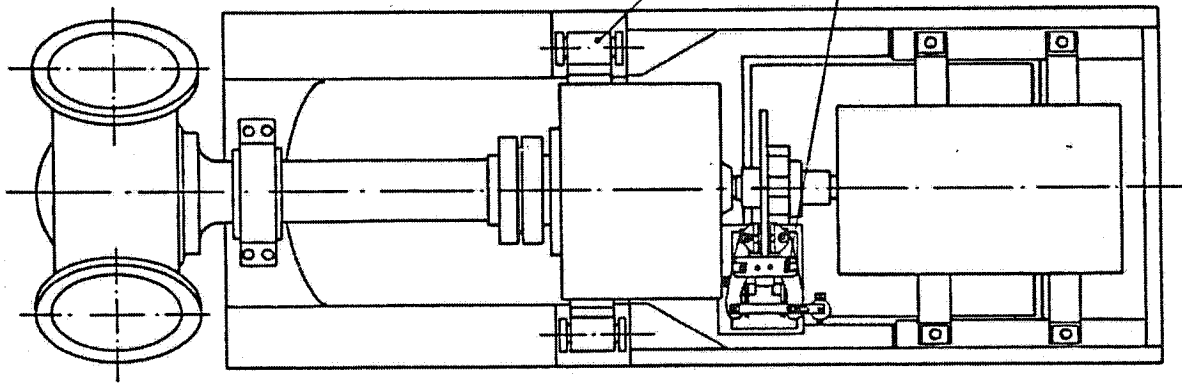

This drawing or any part thereof is copied without approval by		Sign	Date
MICON	Drawn		
	Checked		
	Approved		
Part name:	Part no.:		



TECHNICAL DATA M530 - 250 KW WIND TURBINE

Overall data:

Rotordiameter	:	26 m
Cut in windspeed	:	5 m/s
Cut out windspeed	:	25 m/s
Tip speed	:	56,5 m/s
Hub height	:	30 meter
Survival windspeed	:	
Rotor	:	41,5 RPM
Nacelle tiltangle	:	5°
Regulation	:	Stall

Weight:

Rotor	:	4,000 kg
Nacelle	:	9,000 kg
Tower	:	12,000 kg

Gearbox: : Coaksial

Gear ratio	:	Hansen 1:36,52/ Flender 1:35,94
No. of steps	:	2

Generator:

Rated power output	:	250 kW
Type	:	Asynchronous, three phase
Voltage	:	400 V 50 Hz
Rpm	:	1500 50 Hz

Tower:

Height	:	28.7 m, 24 edged steel plate
Material	:	Hot dip galvanized steel plate
Sections	:	4
Assembling	:	Each section bolted together Longitudinal. The 4 sections are bolted together.
Ladder	:	Inside the tower to admit ac- cess to the nacelle directly.
Safety	:	Safetyline and belt with fall securing device.
Doors	:	To admit service and inspection of blade tips.

Computer Management System:

The control panel can be connected to a computer management system, for remote control of the windfarm. To provide all necessary information from each machine and the windfarm in total.

Nacelle	:	Hot dip galvanized welded steel plate main frame.
<u>Yawsystem</u>	:	Slewingring system with gearmotored yawing.
Orientation	:	Up to electronic wind vane.

Rotor:

Number of blades	:	3
Diameter	:	26 m
Swept area	:	531 m ²
Material	:	Fibreglass reinforced polyester.
Pitch	:	Fixed
Power regulation	:	Stall

Brake system:

Aerodynamics	:	Leading edge spoiler, centrifugal activated at nominal RPM +10% (adjustable).
Mechanical	:	Failsafe disc brake on high speed shaft.

<u>Anemometer:</u>	:	Positioned at the nacelle connected to the control panel computer for instantly information, and to stop at cut-out windspeed 25 m/s.
--------------------	---	---

Service:

Scheduled service and maintenance, every six month, approx. 16 hours per inspection.

20.11.89/JO

Lockable door in bottom section to avoid not authorized admittance to the WTG.

<u>Control panel</u>	:	Mounted inside the tower for climate protection and unauthorized admission.
Function	:	Ensures automatic engagement of generator. Push-buttons with text for simple operation and checking of the turbine. Display with indication of faults ensures quick trouble-shooting in the event of stoppage or breakdown. Automatic start-up after grid failure. Micon wind turbines are equipped as standard with $\cos \phi$ to 0.90. Excess voltage protection by means of lightning arresters. Electronic engaging equipment to restrict current impulses on engagement to 1.3 over voltage protection x top loading of generator.

Safety systems:

1. Centrifugally activated blade-tip brakes.
2. Electro-mechanical "fail-safe" disc brake.
3. Grid control of:
 - a. Voltage $400 \text{ V} \pm 10\%$
 - b. Frequency $50 \text{ Hz} \pm 1 \text{ Hz}$
 - c. Phase equality control
4. Over-speed control on rotor activating disc brake
5. Thermo-detector in generator
6. Vibration control switch.
7. Automatic un-twisting of cables
8. Thermo relay for yaw-gear motor.
9. 90° yaw of nacelle, in case of malfunction.
10. Automatic stop for work brake pads.
11. Automatic start-up in the event of grid failure.
12. Self diagnostic in case of failure. Display indicates failure code.
13. Ready to be linked via modem with Computer Management System.
14. Built-in data-processor.
15. Automatic stop at windspeeds above 25 m/s.

12/13 m

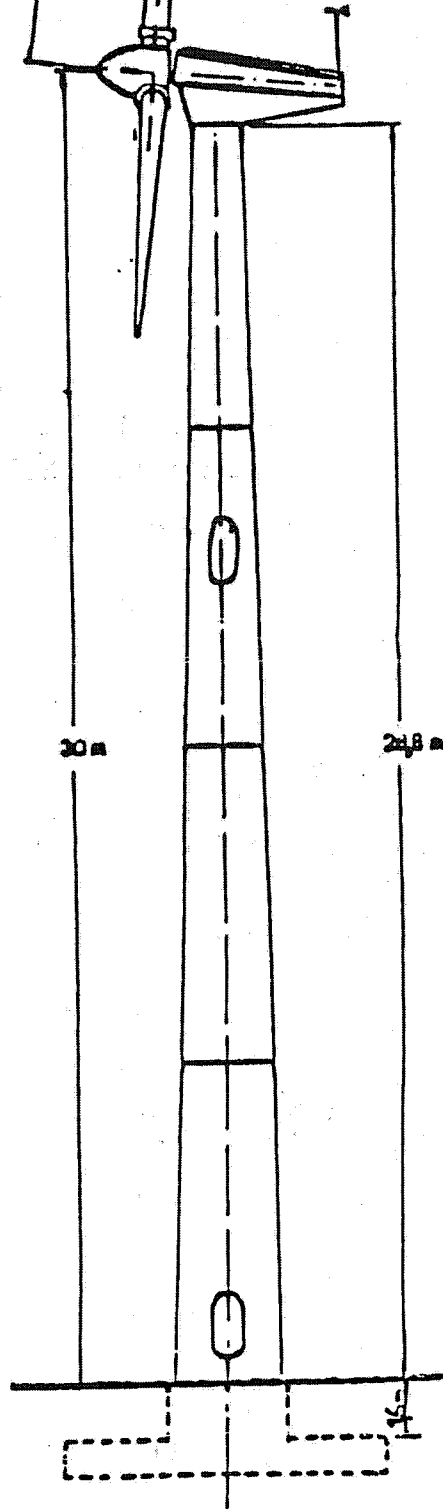

30 m

24.8 m

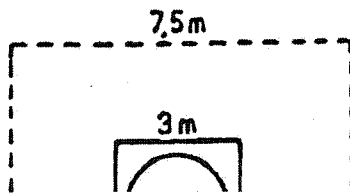

7.5 m

3 m

QUALITY ASSURANCE SYSTEM

Micon has the aim to produce wind turbine generators of a very high quality level to secure both the customer and Micon against technical problems. To achieve this, Micon in 1987 went into a cooperation with "Det Norske Veritas" (DNV). The result of this cooperation is the introduction of a QA system based on following principles:

- The design of the wind turbine is approved by Risø and DNV.
- All components in the wind turbine are delivered with certificates stating that they are in accordance with the approval.
- Transmissions are delivered with test reports.
- For each serie of generators a test report is made on one generator.
- All the steel is delivered with 3.1.B certificates and stamped with charge number.
- The blades are delivered with DNV certificates.
- The mainshaft is delivered with 3.1.B certificates and ultra sound tested.
- All machined parts are measured through by Micon and marked with green sign before they are allowed to be used in the production.
- The weldings are examined by "Svejsecentralen" according to DS 412 welding class B.
- To secure that the assembling of the wind turbine is done correctly, an assembly instruction is made for every part of the wind turbine.
- The fitters sign the mounting instruction, confirming that it is done correctly.
- The wind turbine goes through a final test, where all functions are tested and checked for unnormal noise and vibrations.
- The fitters go through a training programme.
- DNV secures that the QA system at the subcontractors is functioning.

- DNV secures that Micon's QA system is functioning.
- DNV makes QC work on the premises of Micon and subcontractors.
- Based upon the certificates, QC papers, assembly scheems, welding reports, etc. DNV issues a "Product Certificate of Conformity" for each specific turbine.

Since Micon introduced the above described QA system, Micon has delivered 140 pc. M108 kW wind turbines to Cannon Capital Group, California and all delivered Micon M450 and M530 wind turbines.